

Universal, 0 dBd Base Station and Marine Antenna for the 900 MHz Band

DESCRIPTION

- CXL 900-1LW is a 0 dBd, vertically polarized, omnidirectional base station and marine antenna, which covers the 900 MHz band in two models.
- Provided with the sturdy “LW” mast mount – a lightweight, multipurpose, epoxy-coated mounting bracket made of non-corrosive aluminium.
- The accompanying U-bolts and fittings are made of stainless steel.
- To be mounted on vertical or horizontal mast tubes, 16 to 54 mm in outer diameter.
- The cable can be led either on the outside or along the inside of the mast tube.
- Large bandwidth with respect to both VSWR and gain.
- The carefully designed, broad-banded antenna element is sealed in a high-quality, conical glass fibre tube with low wind-load, which will ensure performance undisturbed by corrosive environments.
- To substantially reduce noise caused by atmospheric discharges, all metal parts in the antenna are DC-grounded. Consequently, the antenna shows a DC-short across the coaxial cable.
- The CXL 900-1LW is a vibration-proof, lightweight, slim-line, corrosion resistant, modern style base station and marine antenna.



SPECIFICATIONS

Electrical	
Model	CXL 900-1LW/...
Frequency	Models within 824 - 960 MHz
Antenna Type	Coaxial dipole, broad-banded
Max. Input Power	100 W
Polarisation	Vertical
Pattern Type	Omnidirectional
3 dB Beamwidth, E-Plane	80 °
3 dB Beamwidth, H-Plane	Omnidirectional
Impedance	50 Ω
Gain	0 dBd (2.2 dBi)
VSWR	< 1.5:1
Bandwidth	70 - 90 MHz
Antistatic Protection	All metal parts DC-grounded (Connector shows a DC-short)
HCM Code(s)	HCM000ND00, 040DE00
Mechanical	
Connection(s)	N(f)
Materials	Shroud : Polyurethane-coated glass fibre Mounting bracket : Seawater resistant aluminium, epoxy-coated Clamps : Stainless steel
Colour	White (RAL 9003)
Wind Area	0.012 sq. m / 0.13 sq. ft
Wind Load	14.7 N (160 km/h)
Dia. At Top End	23 mm / 0.9 in.
Dia. At Bottom End	23 mm / 0.9 in.
Height	530 mm / 20.87 in.
Weight	Approx. 0.7 kg / 1.54 lb.
Mounting	On 16 - 54 mm / 0.63 - 2.13 in. dia. mast tube

Environmental	
Operating temperature range	-30 °C to +70 °C
Survival Wind Speed	200 km/h
Ingress Protection	IP66

ORDERING

Model	Product No.	Frequency
CXL 900-1LW/l	110000422	824 - 894 MHz
CXL 900-1LW/h	110000423	870 - 960 MHz

TYPICAL VSWR CURVE

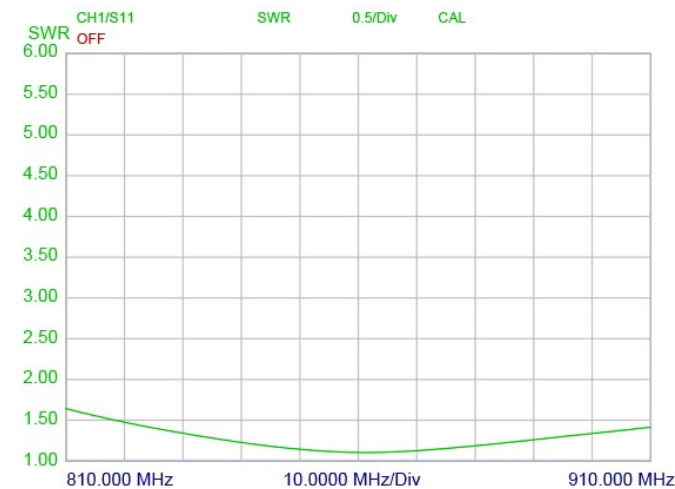

TYPICAL RADIATION PATTERN (H-PLANE)

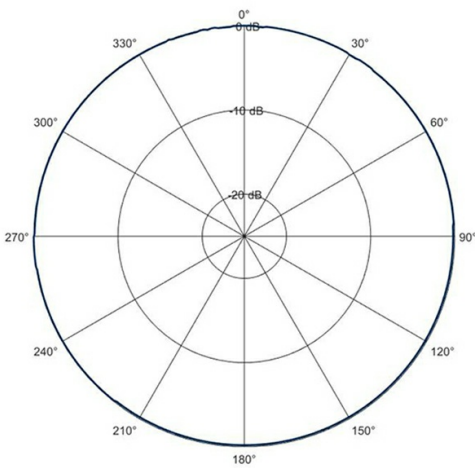

TYPICAL RADIATION PATTERN (E-PLANE)

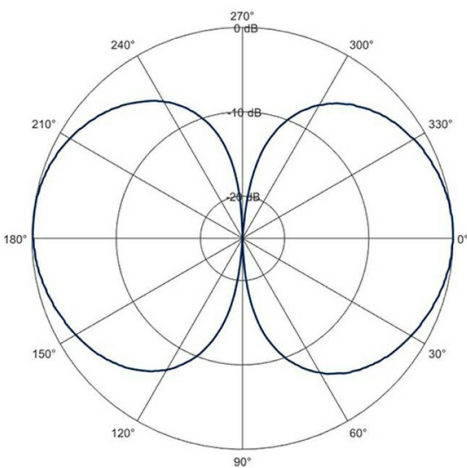

MULTI-PURPOSE MOUNTING BRACKET

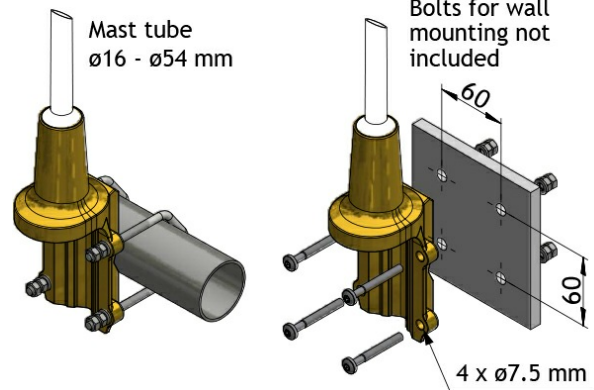
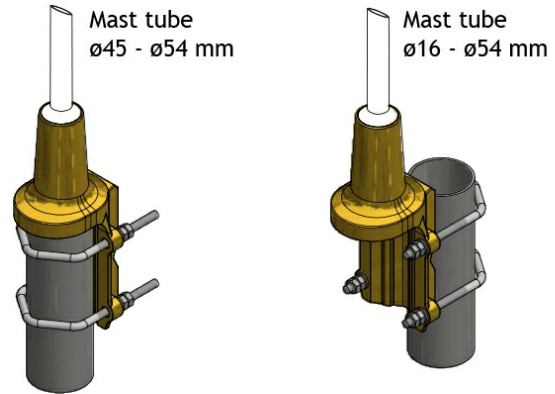

PLEASE NOTE

The antenna is delivered with a DC-connection between the antenna element and the mounting bracket

