

Short Centre-loaded Mobile Antenna for the 27 MHz CB-Band

DESCRIPTION

- Short antenna with attractive appearance ideal for mounting on the car roof.
- High efficiency in spite of low height due to high-Q centre-loading coil and matching unit built into mount.
- Stainless steel ZP4-mount, with ball-joint and wing screw whip-fastening system.
- Simple mounting exclusively with access from the outside.
- Delivered with 4 m cable permanently attached to the mount and terminated with FME-connector.



SPECIFICATIONS

Electrical	
Model	CT 27-ZP4
Frequency	27 MHz CB-band
Antenna Type	Centre-loaded mobile antenna
Max. Input Power	200 W
Polarisation	Vertical
Impedance	50 Ω
VSWR	$\leq 1.3:1$ @ f.res.
Bandwidth	≥ 350 MHz @ VSWR ≤ 1.5
Mechanical	
Materials	Whip : Stainless steel, Nylon, Chromed brass Mount : Chromed brass Weather- and shockproof plastics Stainless steel
Cable	4 m RG 58
Installation Torque	7.5 \pm 1 Nm
Colour	Black / Metallic Silver
Height	Approx. 680 mm / 26.77 in.
Weight	Approx. 0.49 kg / 1.08 lb.
Mounting	21 mm dia. hole (For roof thicknesses 2 mm up to 7.5 mm mounting hole should be 22mm dia.)
Mounting Plate Thickness	Max. 2.0 mm (Models up to 7.5 mm on request)

ORDERING

Model	Product No.
CT 27-ZP4	130000591

INSTALLATION

This antenna is supplied with type ZP4-mount. The whip is fastened to the mount by means of our standard ball-joint and wing screw system. The adjustable ball-joint ensures that the whip can always be mounted in a vertical position independent of the angle of the installation spot.

The ZP4-mount is particularly well suited for mounting on car-roofs because of its ability to be installed exclusively with access from the outside. However, the antenna can be installed anywhere on the car, as the ZP4-mount is equally well suited for mounting on e.g. trunk or wing.

3. TUNING

The antenna should always be post-adjusted using an VSWR-meter, especially if mounted near metal parts parallel to the whip. Loosen the union nut at the top of the coil and pull out the whip approx. 5 mm at a time until best possible VSWR is obtained. Fasten the union nut thoroughly.

PLEASE NOTE

To make this antenna operate as efficiently as possible, a matching unit has been built into the antenna mount. Consequently, neither mount nor whip can be used together with other mounts/whips.

1. INSTALLATION DIMENSION

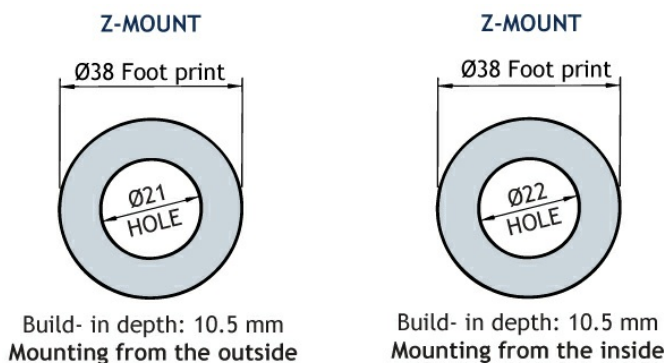

2. INSTALLATION STEPS

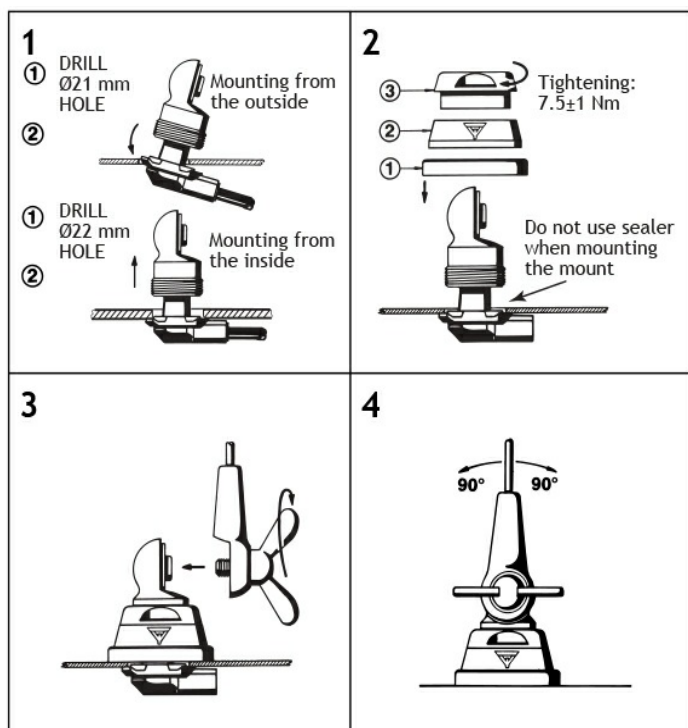

Do not use sealer on rubber gasket or other places.

