

Dual-frequency Mobile Antenna for the 80 and 160 MHz Bands

DESCRIPTION

- New whip design for optimum wind noise reduction.
- This antenna makes it possible to:
 - operate 80 and 160 MHz transceivers alternately on the same antenna
 - operate two transceivers (80 and 160 MHz) at the same time on one antenna using a diplexer (type DIPX 88/136 – must be ordered separately).
- Only a single hole has to be drilled instead of two.
- Car appearance is not destroyed by an “antenna farm”.
- Ideal for covert services.
- Stainless steel Z-mount with ball-joint and wing screw whip-fastening system.
- Simple mounting exclusively with access from the outside.
- Models with roof thickness from 2 mm to 7.5 mm mounting from the inside.
- Choice between two connection principles:
 - Z-mount: FME-connection (supplied without cable).
 - ZP4-mount: Permanently attached 4 m cable terminated with FME-connector.



SPECIFICATIONS

Electrical	
Model	DFA 4/2-Z/...
Frequency	80 MHz-band freq. to be stated within : 66-88 MHz 160 MHz-band freq. to be stated within : 144-175 MHz
Antenna Type	Dual-frequency mobile antenna
Max. Input Power	30 W
Polarisation	Vertical
Impedance	50 Ω
VSWR	≤ 1.5.1 @ f.res.
Bandwidth	80 MHz : ≥ 3 MHz @ VSWR ≤ 2.0:1 160 MHz : ≥ 6 MHz @ VSWR ≤ 2.0:1
Gain (EIA RS-329-1)	0 dB
Mechanical	
Materials	Whip : Conical glass fiber Chromed brass Mount : Chromed brass Weather- and shockproof plastics Stainless steel
Installation Torque	7.5 ± 1 Nm
Colour	Black
Height	Approx. 1100 mm / 43.31 in.
Weight	Z-version : Approx. 170 g ZP4-version : Approx. 320 g
Mounting	21 mm / 0.83 in. dia. hole (For roof thickness 2 mm / 0.08 in. up to 7.5 mm / 0.30 in. mounting hole should be 22 mm dia.)
Mounting Plate Thickness	Max. 2.0 mm / 0.08 in. (Models up to 7.5 mm / 0.30 in. on request)

ORDERING

Model	Product No.	Description	Frequency
DFA 4/2-Z/71.7/149.3	130000665	Z-mount with FME-system	80: TX: 71.7 MHz 80: RX: 76.2 MHz 160: 149.3 MHz
	DFA 4/2-Z/76.5/166.0	Z-mount with FME-system	80: 76.5 MHz 160: 166.0 MHz
DFA 4/2-ZP4/71.7/149.3	130000667	ZP4-mount with 4 m cable and FME-connector	80: TX: 71.7 MHz 80: RX: 76.2 MHz 160: 149.3 MHz
	DFA 4/2-ZP4/76.5/166.0	ZP4-mount with 4 m cable and FME-connector	80: 76.5 MHz 160: 166.0 MHz

THE WHIP IS COMPATIBLE WITH ALL BELOW MOUNTS

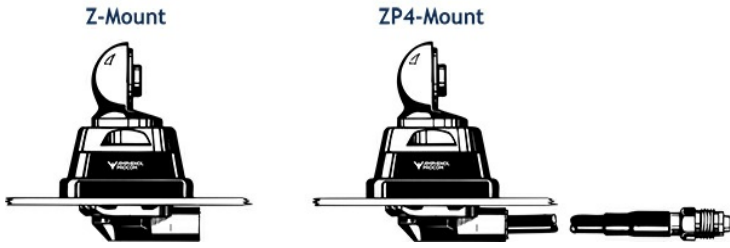

PLEASE NOTE

As standard the antenna is provided with wing screw. However, the wing screw may be replaced by the less obtrusive hat screw (with key), which also gives an improved protection against theft. To order the antenna with hat screw, please add a "K" to the antenna designation.

Hat screw option:

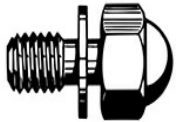

For antenna delivered with hat screw instead of wing screw add a K to the antenna designation.

INSTALLATION

This antenna is supplied with type Z-mount. The whip is fastened to the mount by means of our standard ball-joint and wing screw system. The adjustable ball-joint ensures that the whip can always be mounted in a vertical position independent of the angle of the installation spot.

The Z-mount is particularly well suited for mounting on car-roofs because of its ability to be installed exclusively with access from the outside. The Z-Mount for roof thickness from 2 mm to 7.5 mm must be mounted from the inside. However, the antenna can be installed anywhere on the car, as the Z-mount is equally well suited for mounting on e.g. trunk or wing.

1. INSTALLATION DIMENSION

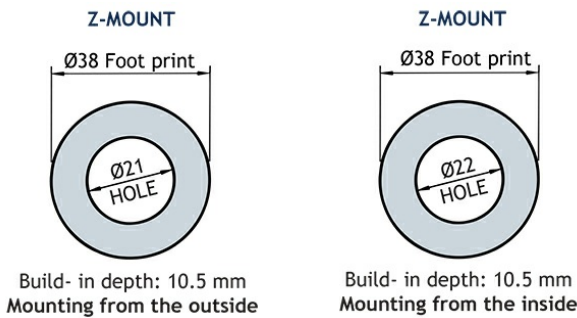

2. INSTALLATION STEPS

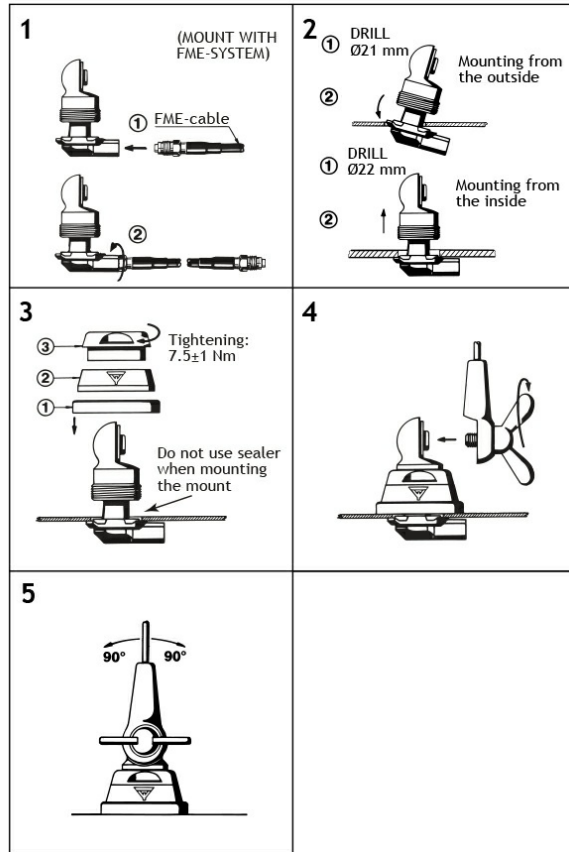

Do not use sealer on rubber gasket or other places.

3. OPERATION USING A DIPLEXER

Several advantages are gained by using only one antenna. Only one single hole has to be drilled into the car body, only one cable installation has to be run, the car appearance is not destroyed by carrying several whips and also, it may be a particular demand that it should not be too obvious to see that the car is equipped with transceiving equipment.

In case of operating two transceivers on one antenna at the same time, a diplexer, type DIPX 225/330 is necessary to complete the system. (See the coupling diagram below). The tasks of the diplexer are to protect the two receiver inputs from being destroyed by the transmitter in the contrary band, and to ensure a low-loss path between the transceiver and the antenna, which is not loaded by the other branch. For further details please see the separate data sheet on the DIPX 225/330.

The diplexer fully covers both bands and, consequently, tuning to specific frequencies is not required.

CONNECTION DIAGRAM

