

Band-Pass Filter for the 450 MHz Band

DESCRIPTION

- The BPF 70/4 is a 4 resonator $\frac{1}{4} \lambda$ band-pass filter with inductive coupling between the resonators.
- This filter can be used as a preselector to protect a receiver from interference from transmitters outside the band-pass limits.
- When installed at the output of a transmitter, the BPF 70/4 reduces spurious signals.
- The BPF 70/4 is adjustable over the range 380 - 470 MHz.
- Careful choice of materials ensures reliable functioning over a wide temperature range.
- Extruded aluminium sections, steel racks and coax cables and connectors with teflon insulation ensure good mechanical strength.
- BPF 70/4 is coated with black vinyl to prevent corrosion.
- The filter is delivered in standard version with 4 MHz bandwidth, other bandwidths can be requested when ordering (up to 10 MHz)



SPECIFICATIONS

Electrical	
Model	BPF 70/4
Filter Type	Band-pass filter
Frequency	380 - 470 MHz
Max. Input Power	50 W
Insertion Loss	< 1.5 dB
Impedance	50 Ω
Reject Attenuation	See curve
VSWR	< 1.5:1
Bandwidth	4 MHz - 10 MHz (Specify when ordering)

Mechanical	
Connection(s)	N(f) (BNC(f), TNC(f), UHF(f) or SMA(f) on request)
Dimensions	208 (without connectors) x 104 x 33 mm / 8.19 x 4.09 x 1.3 in.
Weight	Approx. 0.69 kg / 1.52 lb.

Environmental	
Operating temperature range	-30 °C to +60 °C

ORDERING

Model	Product No.
BPF 70/4 N(f)	200000925

TYPICAL RESPONSE CURVE

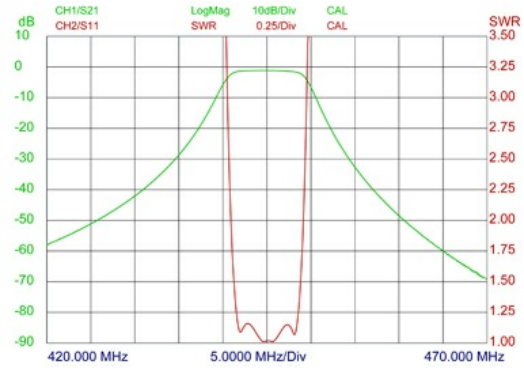

MOUNTING DETAILS

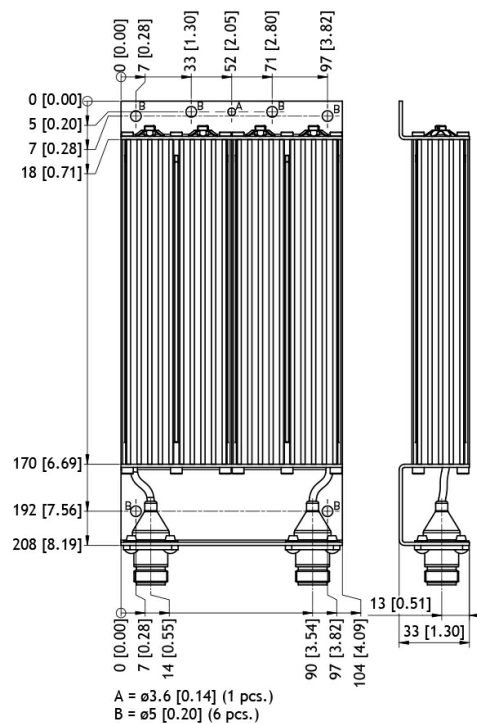

All dimensions are given in mm [in.]

