

colinear, 3 dBd Ground-Plane Base Station and Marine Antenna for the 450 MHz Band

DESCRIPTION

- The high gain of this antenna combined with its low height makes it the right choice for a wide variety of purposes.
- The antenna is delivered in two models tunable by cutting within 380...410 MHz (l-version) and 406...470 MHz (h-version), respectively.
- The GP 450-3/... is especially suitable as a marine antenna in connection with 450 MHz cellular radio telephone systems making it possible to extend the normally land-based cellular system for maritime mobile service as well.
- The compactness of the GP 450-3/... also makes it highly qualified as a base station antenna.
- The higher the antenna is mounted, the better coverage. Avoid mounting the antenna parallel to or in the neighbourhood of other metal parts such as masts, supporting wires etc., otherwise the VSWR and the radiation pattern may be influenced.
- The antenna is easily field-tuned following the instructions below, or it can be ordered factory-tuned for CELLULAR or customer-specified frequencies. See ordering information below.
- Materials used are 18/8 stainless steel, UV-stabilized plastic and triple-plated chromed brass.

PLEASE NOTE: The GP 450-3/... can also be delivered factory tuned to a specific frequency or cellular network, such as TETRA. In this case, please add frequency or name of the network to the antenna model, e.g. GP 450-3/390 MHz.

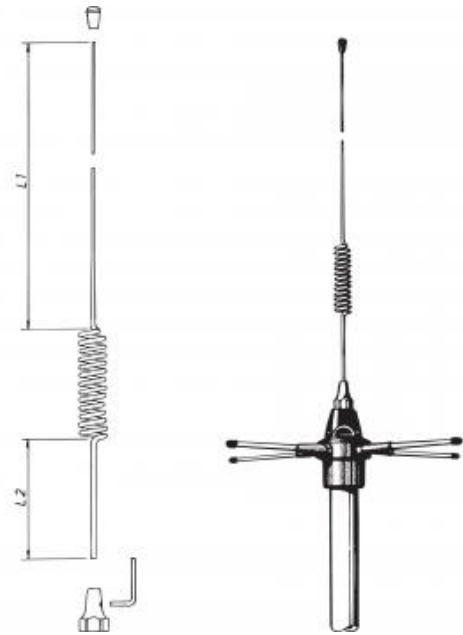

SPECIFICATIONS

Electrical	
Model	GP 450-3/...
Frequency	Tunable by cutting within : l : 380 - 410 MHz h : 406 - 470 MHz
Antenna Type	Collinear ground-plane antenna
Max. Input Power	250 W
Polarisation	Vertical
Pattern Type	Omnidirectional
3 dB Beamwidth, H-Plane	Omnidirectional
Impedance	50 Ω
Gain	3 dBd (5.2 dBi)
Bandwidth	10 MHz @ VSWR < 1.5

Mechanical	
Connection(s)	N(f)
Materials	Bright polished stainless steel. Bright chromed brass. Weather- and shockproof plastics
Colour	Metallic Silver
Wind Area	0.0131 sq. m / 0.14 sq. ft
Wind Load	17 N (160 km/h)
Dia. At Top End	2 mm / 0.08 in.
Dia. At Bottom End	3 mm / 0.12 in.
Height	Approx. 730 mm / 28.74 in.
Weight	Approx. 0.78 kg / 1.72 lb.
Mounting	On 27 / 1.06 in. dia. mast tube

Environmental

Operating temperature range	-30 °C to +70 °C
-----------------------------	------------------

ORDERING

Model	Product No.	Frequency
GP 450-3/l	100000134	Tunable within 380 - 410 MHz
GP 450-3/h	100000135	Tunable within 406 - 470 MHz

PLEASE NOTE

The GP 450-3/... can also be delivered factory tuned to a specific frequency or cellular network, such as TETRA. In this case, please add frequency or name of the network to the antenna model, e.g. GP 450-3/390 MHz.

CUTTING DIAGRAM

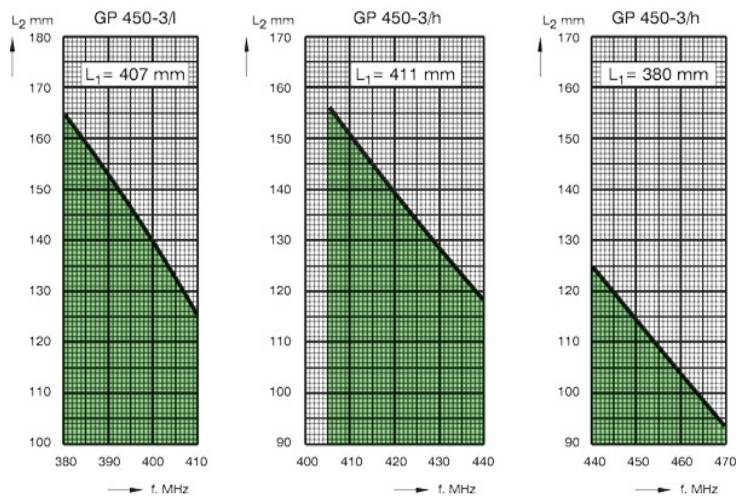

TUNING INSTRUCTIONS

The GP 450-3/... must be tuned to the operating frequency according to the following instructions:

- Only for GP 450-3/h: Cut the top section (L₁) above the phasing coil as indicated in the cutting diagram, depending on whether operating in the lower end or the higher end of the band 406 - 470 MHz.
- Tune the antenna using an VSWR-meter by cutting the bottom end of the whip (L₂). The whip is loosened from the nipple using the accompanying hex key. Use the cutting diagram above as a guide for this procedure.

Do not cut the radials.

